



Broadcast quality 3G/HD/SD-SDI, 10/100 Ethernet and 2 channels of RS-Type data over one single mode or two multimode fibers. All data channels are available simultaneously!

## Fiberlink® 3370 Series

**3G/HD/SD-SDI Transmission and  
10/100 Ethernet & 2 Channels of RS-Type Data  
over one single mode or two multimode fibers.**



**CSI** Communications  
Specialties, Inc.

### **World Headquarters**

55 Cabot Court  
Hauppauge, New York 11788 USA  
Tel: (631) 273-0404  
Fax: (631) 273-1638  
info@commspecial.com

**commspecial.com**

## Contents

Welcome .....	3
Features .....	3
Package Contents .....	3
Technical Specifications	
Model Part Number Specifications .....	4
General Specifications .....	4
Transmitter Specifications .....	5
Receiver Specifications .....	6
Operating Loss Budgets .....	7
Maximum Useable Distance .....	7
Alarm Switch Settings .....	8
Installation Instructions .....	8
Data Configuration (Box Version) .....	10
Baud Rate Settings .....	11
Ethernet Settings .....	12
RS-Type Data Settings .....	12
Data Wiring .....	13
Data Configuration (Card Version) .....	14
Baud Rate Settings .....	15
Ethernet Settings .....	16
RS-Type Data Settings .....	16
Data Wiring .....	17
Indicator LEDs .....	18
Operating Pointers .....	20
Troubleshooting .....	20
Maintenance and Repairs .....	21
Certifications .....	21
Warranty .....	22
Accessories and Related Products .....	23

## Welcome

Thank you for purchasing Communications Specialties, Inc.'s Fiberlink® 3370 Series. The 3370 Series is used to transmit 3G/HD/SD-SDI over one single mode fiber or two multimode fibers as well as 10/100 Ethernet and two channels of RS-Type data. The Fiberlink 3370 series is compatible with single mode or multimode fiber. The system delivers noise-free transmission that retains all of the signals' initial parameters, regardless of fiber optic cable attenuation. The 3370 Series also provides immunity to video pathological signals over the entire link budget and operating temperature range.

## Features

- Transmit up to 2 channels of bi-directional RS-Type data.
- Transmit 10/100 Base-T Ethernet
- All data and ethernet channels available simultaneously
- SDI signal is equalized and re-clocked prior to fiber optic transmission
- Receiver features a re-clocked SDI output
- Immunity to pathological patterns over entire link budget and operating temperature range
- Compliant with SMPTE 259M-2006, 292-2006, 424M-2006, 276M
- Supports one single mode fiber or two multimode fibers
- Supports 3G/HD/SD-SDI inputs with or without embedded audio and data
- 14 dB Optical Link Budget @ 2.97 Gbps
- Wide operating temperature range: -10° C to +50° C
- Available in Box and Card versions
- ST or LC connectors available
- Designed and Manufactured in the USA by CSI

## Package Contents

- One Fiberlink® Unit (3370, 3371, 3372 or 3373)
- This User's Manual
- One Ethernet Crossover Cable

## Technical Specifications

### Model Part Number Specification

Unit Type	Part Number
Transmitter Box (1 Fiber, SM)	3370-B7L (LC) 3370-B7S (ST)
Transmitter Rack Card (1 Fiber, SM)	3370-C7L (LC) 3370-C7S (ST)
Receiver Box (1 Fiber, SM)	3371-B7L (LC) 3371-B7S (ST)
Receiver Rack Card (1 Fiber SM)	3371-C7L (LC) 3371-C7S (ST)
Transmitter Box (2 Fiber, MM)	3372-B7L (LC) 3372-B7S (ST)
Transmitter Rack Card (2 Fiber, MM)	3372-C7L (LC) 3372-C7S (ST)
Receiver Box (2 Fiber, MM)	3373-B7L (LC) 3373-B7S (ST)
Receiver Rack Card (2 Fiber MM)	3373-C7L (LC) 3373-C7S (ST)

### General Specifications

Indicators	Power, Data Rate lock (3G, HD, SD), Alarm (card version only), RS-Data Channel 1, RS-Data Channel 2 & Ethernet LEDs on RJ-45 Connector
Box Version Dimensions	6.5 W x 1.15 H x 8 L (inches) 165 W x 29 H x 203 L (mm)
Weight	approx. 1 lb.; 0.45 kg
Number of slots in 6000A card cage	2
Power	9-24 volts, AC or DC 3370: 4.8 watts, 16.4 BTU/Hr 3371: 4.65 watt s, 15.87 BTU/Hr
Operating Temperature	-10°C to +50°C
MTBF	36,000 Hours

### Data Specifications:

Data Channels	2 Channels, Bi-Directional
Data Bandwidth	DC to 115 Kb/sec, max.
Control Format	Switch selectable RS-232, RS-422 & RS-485 (4 wire or 2 wire);
Protocols	NRZ, NRZI, RZ, Manchester, Bi-phase
Signal Connectors:	Removable terminal block Data

## Technical Specifications

### Ethernet Specifications:

Port:	10/100 Base-T, RJ-45 connector, Configured as MDI
Speed:	10 Mbps & 100 Mbps Ethernet, Switch Selectable

### Fiberlink 3370 Transmitter Specifications:

#### Serial Video BNC Input Specifications

Channels	2 Channels, Bi-Directional
Data Bandwidth	DC to 115 Kb/sec, max.
Control Format	Switch selectable RS-232, RS-422 & RS-485 (4 wire or 2 wire);
Protocols	NRZ, NRZI, RZ, Manchester, Bi-phase
Signal Connectors:	Removable terminal block Gbps and 350m at 270 Mbps
Return Loss	>10dB up to 2.97 Gbps

#### Fiber Optic Output Specifications

Connector	LC or ST
Wavelengths Used	1310nm, 1490nm, 1550nm
Emmitter Type	FP Laser
Output Power ( <i>nominal</i> )	-4.5 dBm
SDI Re-clocking	At 270 Mbps, 1.485 Gbps & 2.97 Gbps

## Technical Specifications

### Fiberlink 3371 Receiver Specifications:

#### Fiber Optic Input Specifications

Connector	LC or ST
Wavelength	1100 - 1620 nm
Minimum Input Sensitivity	-17 dBm at 2.97 Gbps; -22 dBm at 1.485 Gbps; -24 dBm at 270 Mbps;
Maximum Input Power	0 dBm

#### Serial Video BNC Output Specifications

Number of Outputs	1
Signal Level	800mV $\pm$ 10%
DC Offset	0V $\pm$ 0.5V
Rise/Fall Time	< 135 ps at 2.97 Gbps per SMPTE 424M; < 270 ps at 1.485 Gbps per SMPTE 292; 0.4 ns to 1.5 ns at 270 Mbps per SMPTE 259M
Overshoot	< 10% of amplitude
Timing Jitter	< 0.2 UI at 270 Mbps; < 1.0 UI at 1.485 Gbps; < 2.0 UI at 2.97 Gbps with color bar signal
Alignment Jitter	< 0.2 UI at 270 Mbps; < 0.2 UI at 1.485 Gbps; < 0.3 UI at 2.97 Gbps with color bar signal
Re-clocking	At 270 Mbps, 1.485 Gbps & 2.97 Gb

**Fiberlink 3371 Receiver Specifications:****Operating Loss Budget**

Single Mode Fiber	0-14 dB at 2.97 Gbps 0-17 dB at 1.485 Gbps 0-20 dB at 270 Mbps
Multimode Fiber (62.5u)	0-14 dB at 2.97 Gbps 0-17 dB at 1.485 Gbps 0-20 dB at 270 Mbps
Multimode Fiber (50u)	0-14 dB at 2.97 Gbps 0-17 dB at 1.485 Gbps 0-20 dB at 270 Mbps

**Maximum Useable Distance\***

Single Mode Fiber	30 km at 2.97 Gbps 48 km at 1.485 Gbps 50 km at 270 Mbps
Multimode Fiber (62.5u)	0.8 km at 2.97 Gbps 1 km at 1.485 Gbps 2.5 km at 270 Mbps
Multimode Fiber (50u)	1 km at 2.97 Gbps 1.3 km at 1.485 Gbps 3 km at 270 Mbps

\*Distance specifications are approximate, based upon connecting a 3370 Transmitter to a 3370 Receiver, and are not guaranteed. CSI cannot estimate or guarantee operating loss budgets when the 3370 Series is used with other, non-Fiberlink devices. Operating loss budget must not be exce

## Alarm Switch Settings & Options

The Rack Card version of this product has an additional red indicator LED that illuminates when an alarm condition exists.

The rack card unit also provides an output to drive a model 6020A Alarm Sensing Module which provides an audible tone and activates a set of contacts for external signaling purposes.

Alarm Switch Settings for the Transmitter Card			
Switch Position	Alarm Indication	On	Off
1	Loss of Input Video	Enabled	Disabled
2	N/A	N/A	N/A

Alarm Switch Settings for the Receiver Card			
Switch Position	Alarm Indication	On	Off
1	Loss of Optical Signal	Enabled	Disabled
2	N/A	N/A	N/A

## Installation Instructions

The Fiberlink® 3370 Series of fiber optic transmission systems are ready for immediate use and do not require any special tools or equipment.

### The following instructions describe the typical installation procedure:

- 1) Connect the video source to the video input BNC connector on the transmitter unit.
- 2) (Optional) Connect your data connections as described in the Data Wiring section of this manual.
- 3) Connect the video output cable to the video output BNC connectors on the receiver unit.
- 4) (Optional) The ethernet port is configured as an MDI port. If you are **not** connecting the 3370 Series to an auto-crossover ethernet port, you may need to use the ethernet crossover cable supplied with the unit to connect to another MDI port.
- 5) (Optional) Connect your data connections as described in the Data Wiring section of this manual.



## Installation Instructions (cont.)

- 6) Connect the fiber optic cable(s) to the transmitter and receiver units.  
**Note: when using two fiber version, you must connect the transmitters Optical A to the receivers Optical A and the transmitters Optical B to the receivers Optical B.**
- 7) Connect the Universal Power Supply to the transmitter and receiver units.  
 For box versions using DC power, please refer to figure 1.
- 8) Configure your data preferences as described in the Data Configuration section of this manual.
- 9) When power is applied, the green POWER LED should illuminate, indicating the presence of operating power. The 3G/HD/SD RATE LED and the audio LEDs will give an indication as described in the Indicator LED's and Alarm Circuitry section of this manual.
- 10) The system should now be operational.

*Note: The Rack Card version has an additional red LED for indicating the presence of an alarm condition (loss of signal). Refer to Indicator LED's and Alarm Circuitry sections of this manual.*

**Figure 1:**  
**Power Connector**  
**DC Input Polarity**

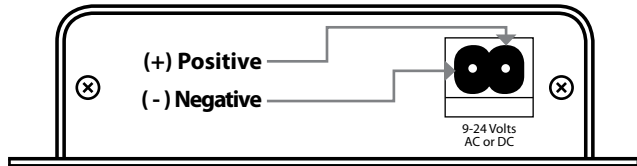

**DANGER!**

The transmitting element in the Fiberlink® 3370 transmitter unit contains a solid state Laser Diode located in the optical connector. This device emits invisible infrared electromagnetic radiation which can be harmful to human eyes. The radiation from this optical connector, if viewed at close range with no fiber optic cable connected to the optical connector, may be sufficient intensity to cause instantaneous damage to the retina of the eye. Direct viewing of this radiation should be avoided at all times!

### Data Configuration (Box Version):

The Fiberlink 3370 Series box units have two dip switch panels, one with 10 switches, one with 9. The first panel, "Data Config A", represents the Ethernet and RS Channel A configuration. The second panel, "Data Config B", represents RS Channel B configuration. Note that all data channels are available simultaneously.

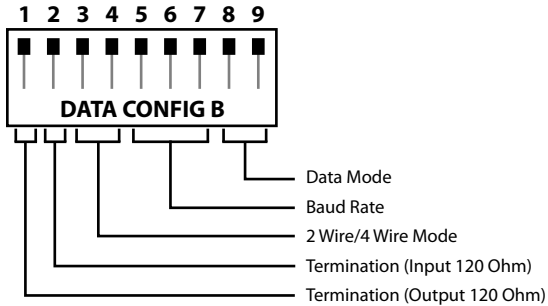
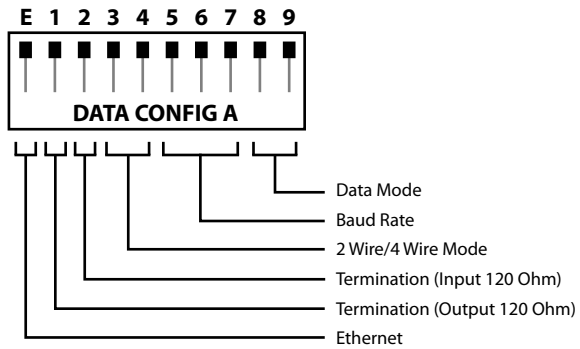

**Baud Rate Configuration**

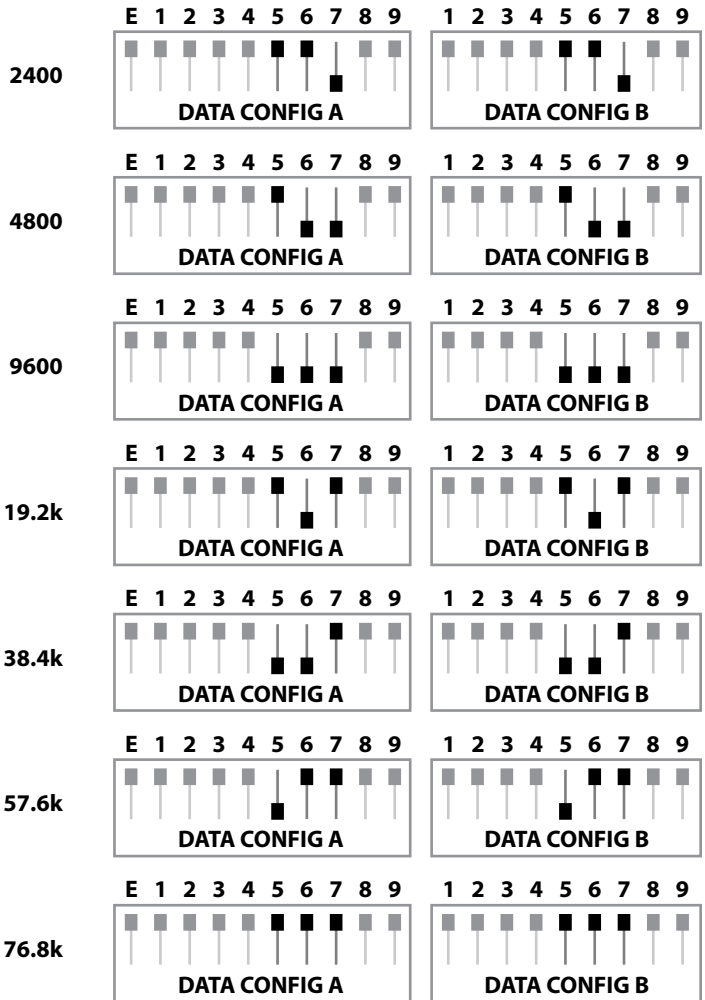

**Ethernet Configurations**

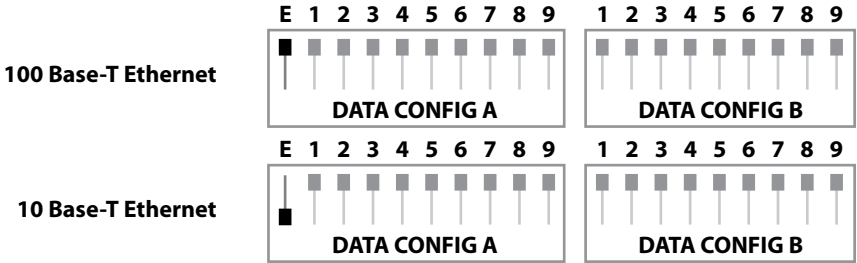

**RS-232**

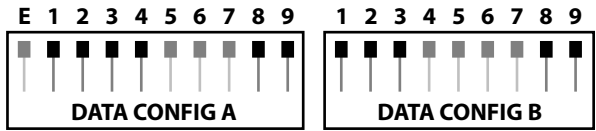

**RS-485/422 4 Wire**

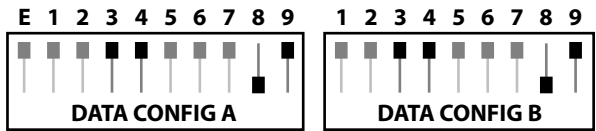

**RS-485 2 Wire T/R**

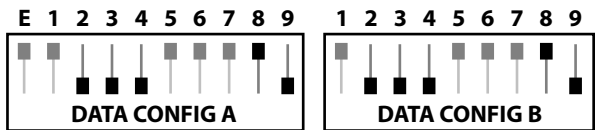

### Data Wiring:

RS-Type data wiring for the Fiberlink 3370 Series is as follows:

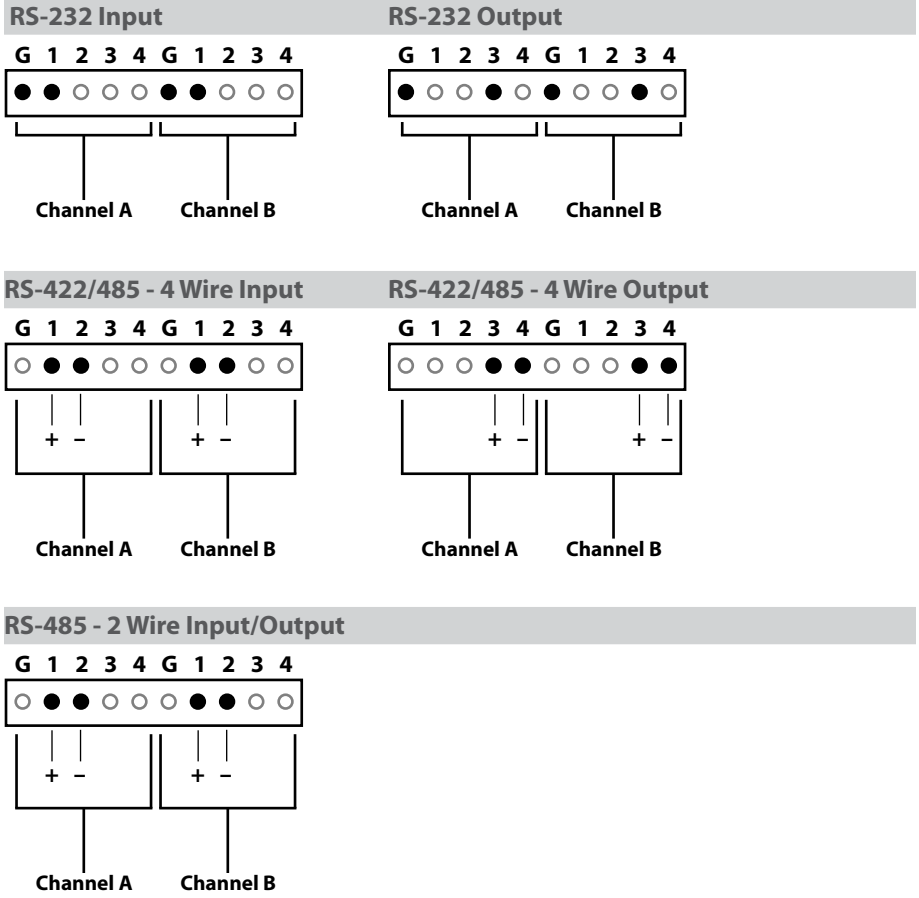

### Data Configuration (Card Version):

The Fiberlink 3370 Series card units have two dip switch panels with 10 switches. The first panel, "DATA CONFIG A", represents the Ethernet and RS Channel A configuration. The second panel, "DATA CONFIG B", represents RS Channel B configuration. Note that all data channels are available simultaneously.

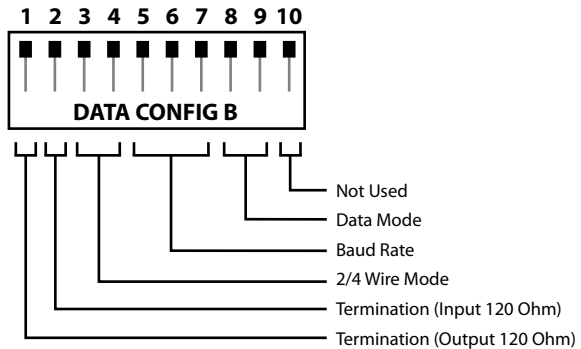
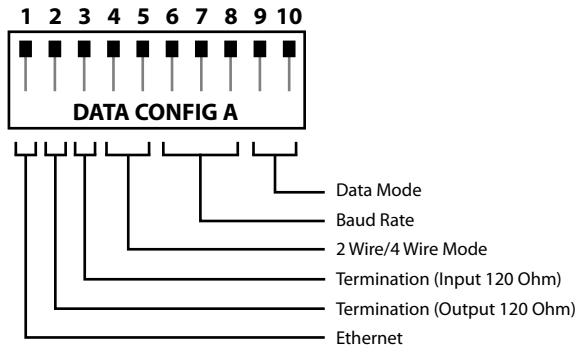

**Baud Rate Configuration**

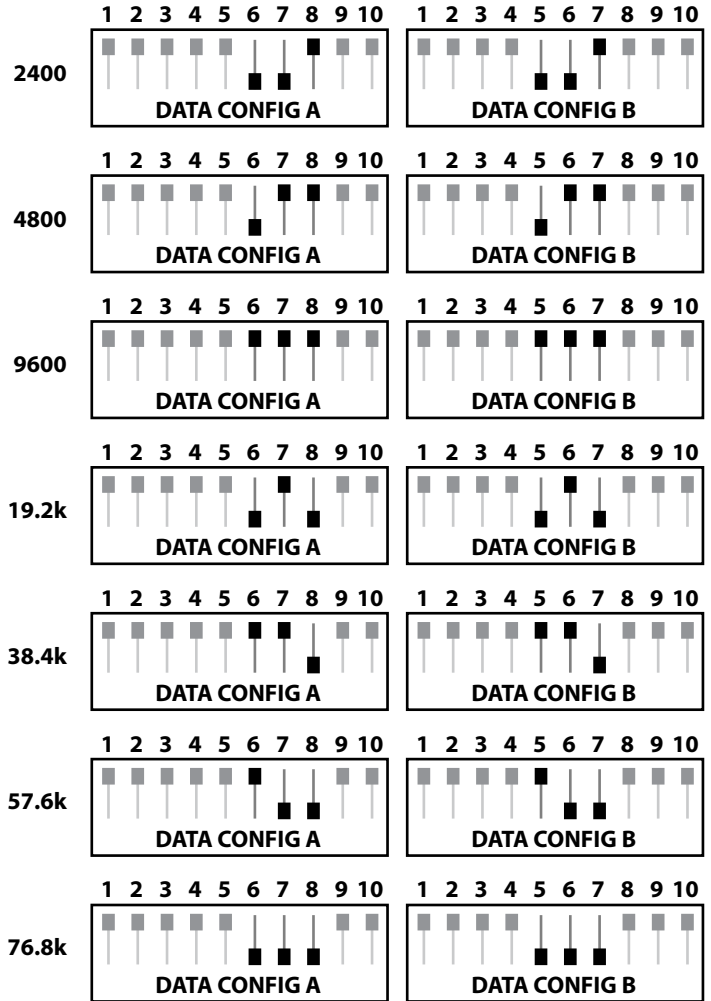

**Ethernet Configurations**

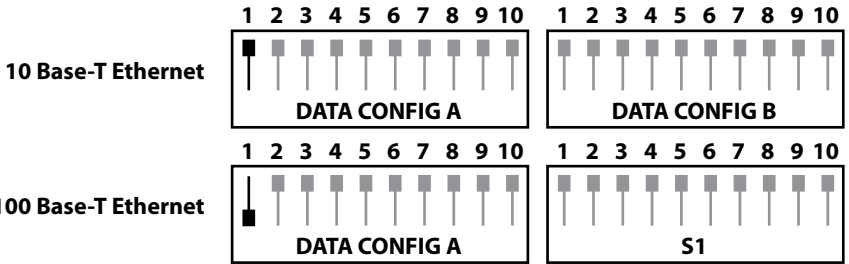

**RS-232**

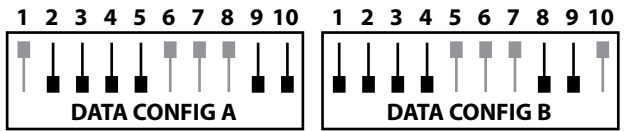

**RS-485/422 4 Wire**

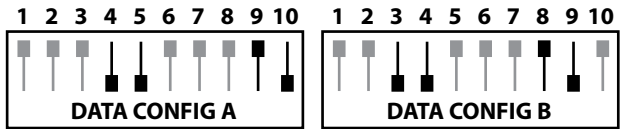

**RS-485 2 Wire T/R**

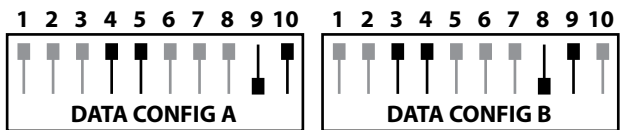



### Data Wiring:

RS-Type data wiring for the Fiberlink 3370 Series card units is as follows:

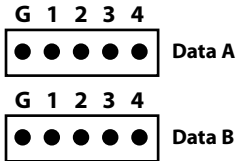

#### RS-232 Input

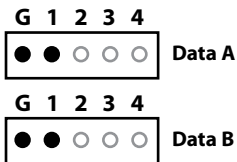

#### RS-232 Output

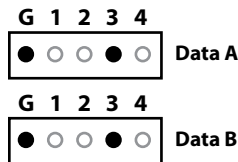

#### RS-422/485 - 4 Wire Input

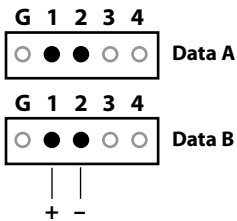

#### RS-422/485 - 4 Wire Output

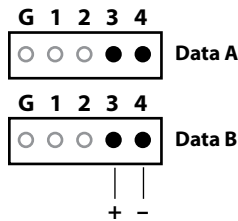

#### RS-485 - 2 Wire Input/Output

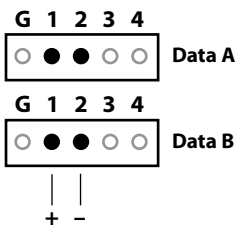

## Indicator LEDs

The Fiberlink® 3370 Series has several indicator LEDs that are used to monitor the state of the unit. Card versions have an additional Alarm LED.

### Transmitter LEDs

LED	Status	Definition
Power	On	Indicates that correct power has been applied.
3G Rate	Off On	Indicates no 3G-SDI data rate lock Indicates 3G-SDI data rate lock at 2.97 Gbps or 2.97/1.001 Gbps
HD Rate	Off On	Indicates no HD-SDI data rate lock Indicates HD-SDI data rate lock at 1.485 Gbps or 1.485/1.001 Gbps
SD Rate	Off On	Indicates no SD-SDI data rate lock Indicates SD-SDI data rate lock at 270 Mbps
Data A	Off Blink	Indicates no data present Indicates data present (electrical or optical)
Data B	Off Blink	Indicates no data present Indicates data present (electrical or optical)
Alarm	On	Loss of input video (card version only)

*Note: The 3G, HD and SD LEDs indicators are off when a non-standard signal is applied.*

## Receiver LEDs

LED	Status	Definition
Power	On	Indicates that correct power has been applied.
3G Rate	Off On	Indicates no 3G-SDI data rate lock Indicates 3G-SDI data rate lock at 2.97 Gbps or 2.97/1.001 Gbps
HD Rate	Off On	Indicates no HD-SDI data rate lock Indicates HD-SDI data rate lock at 1.485 Gbps or 1.485/1.001 Gbps
SD Rate	Off On	Indicates no SD-SDI data rate lock Indicates SD-SDI data rate lock at 270 Mbps
Data A	Off Blink	Indicates no data present Indicates data present (electrical or optical)
Data B	Off Blink	Indicates no data present Indicates data present (electrical or optical)
Alarm	On	Loss of optical signal (card version only)

*Note: The 3G, HD and SD LEDs indicators are off when a non-standard signal is applied.*

## Operating Pointers

Remember to check attenuation of the fiber optic cable. The system will only operate properly if these specifications fall within the range of the system's loss budget.

Note: If no signal is applied to the 3370 Transmitter, no optical power will be present on the 3370 Transmitter's output.

## Troubleshooting

Multimode fiber optic cable contains an optical fiber with a light carrying "core" that is only .0025 inches (62.5 microns) in diameter. Single mode fiber optic cable has an even smaller "core," only .00032 to .0004 inches (8-10 microns). This is smaller than a human hair! Therefore, any minute particles of dirt or dust can easily block the fiber from accepting or radiating light. To prevent this from happening, always use the provided dust caps when ever optical connectors are exposed to air. It is also a good idea to gently clean the tip of an optical connector with a lint-free cloth moistened with alcohol whenever dust is suspected.

The status of the LEDs should provide the first clue as to the origin of any operational failure. If these are off, it usually means that the fiber is broken or has too much attenuation. Next, be certain that the input and output signal connections are correct.

An optical power meter, such as the Fiberlink® 6615, a visible light source, such as the Fiberlink® 6610, and a Three Wavelength Light Source, such as the Fiberlink® 6620, can greatly assist and expedite troubleshooting of fiber optic transmission systems and are recommended tools all installers should have available.

Finally, although multimode and single mode devices may look the same, they will not operate properly together. Using the wrong device or fiber can easily add more attenuation than specified, resulting in poor overall performance. It should be noted that some of our fiber optic products support both single mode and multimode fiber in the same unit.

If, after reviewing the above possibilities, the system is still not operating, please contact the Customer Service Department for further assistance. If you suspect your problem is caused by the optics or the fiber optic cable, and you have an optical power meter, please take the appropriate measurements prior to contacting support.

## Maintenance and Repairs

The Fiberlink® 3370 Series has been manufactured using the latest semiconductor devices and techniques that electronic technology has to offer. They have been designed for long, reliable and trouble-free service and are not normally field repairable.

Should difficulty be encountered, Communications Specialties maintains a complete service facility to render accurate, timely and reliable service of all products.

The only maintenance that can be provided by the user is to ascertain that optical connectors are free of dust or dirt that could interfere with light transmission and that electrical connections are secure and accurate. Please see the Troubleshooting section of this manual for additional information.

An optical power meter, such as the Fiberlink® 6615, a visible light source, such as the Fiberlink® 6610, and a Three Wavelength Light Source, such as the Fiberlink® 6620, can greatly assist and expedite troubleshooting of fiber optic transmission systems and are recommended tools all installers should have available.

All other questions or comments should be directed to our Customer Service Department. It should be noted that many “problems” can easily be solved by a simple telephone call.

If you suspect your problem is caused by the optics or the fiber optic cable, and you have an optical power meter, please take the appropriate measurements prior to contacting support.

---

## Certifications





Communications Specialties, Inc. (CSI) warrants that, for a period of three years after purchase by the Buyer, this product will be free from defects in material and workmanship under normal use and service. A Return Material Authorization (RMA) number must be obtained from CSI before any equipment is returned by the Buyer. All materials must be shipped to CSI at the expense and risk of the Buyer.

CSI's obligation under this warranty will be limited, at its option, to either the repair or replacement of defective units, including free materials and labor. In no event shall CSI be responsible for any incidental or consequential damages or loss of profits or goodwill.

CSI shall not be obligated to replace or repair equipment that has been damaged by fire, war, acts of God, or similar causes, or equipment that has been serviced by unauthorized personnel, altered, improperly installed, or abused.

RMA numbers and repairs can be obtained from:

**Communications Specialties, Inc.**

55 Cabot Court

Hauppauge, NY 11788 USA

Tel: (631) 273-0404

Fax: (631) 273-1638

RMA numbers can also be obtained from our web site: [commspecial.com](http://commspecial.com)

**Please have your serial number available.**



### **Fiberlink® 6610 Visible Light Source**

The Fiberlink® Visible Light Source provides a visible 650 nm laser output that can be used for identifying fiber breaks and individual fibers within fiber bundles, allowing for convenient, on-site testing of fiber networks during construction and maintenance procedures.



### **Fiberlink® 6615 Optical Power Meter**

The Fiberlink® Optical Power Meter measures the power of optical signals at 850, 980, 1310 and 1550 nm wavelengths, allowing for convenient, on-site testing of fiber networks during construction and maintenance procedures. It can be used to measure the power of an optical signal reaching the receiving end of a fiber optic cable, as generated either by a transmitter unit or by a light source such as the 6620.



### **Fiberlink® 6620 Three Wavelength Light Source**

The Fiberlink® Three Wavelength Light Source offers a laser output at wavelengths of 1310 and 1550 nm and VCSEL output at 850 nm, allowing for convenient, on-site testing of fiber networks during construction and maintenance procedures.



## Fiberlink® 3370 Series

**3G/HD/SD-SDI Transmission and  
10/100 Ethernet & 2 Channels of RS-Type Data  
over one single mode or two multimode fibers.**



**CSI Communications  
Specialties, Inc.**

### **World Headquarters**

55 Cabot Court  
Hauppauge, New York 11788 USA  
Tel: (631) 273-0404  
Fax: (631) 273-1638  
info@commspecial.com

**commspecial.com**

©2011 Communications Specialties, Inc.  
All Rights Reserved.

Fiberlink and the starburst logo are  
registered trademarks of  
Communications Specialties, Inc.

CSI and the triangle designs are trademarks  
of Communications Specialties, Inc.

P/N 128916 Rev. E